

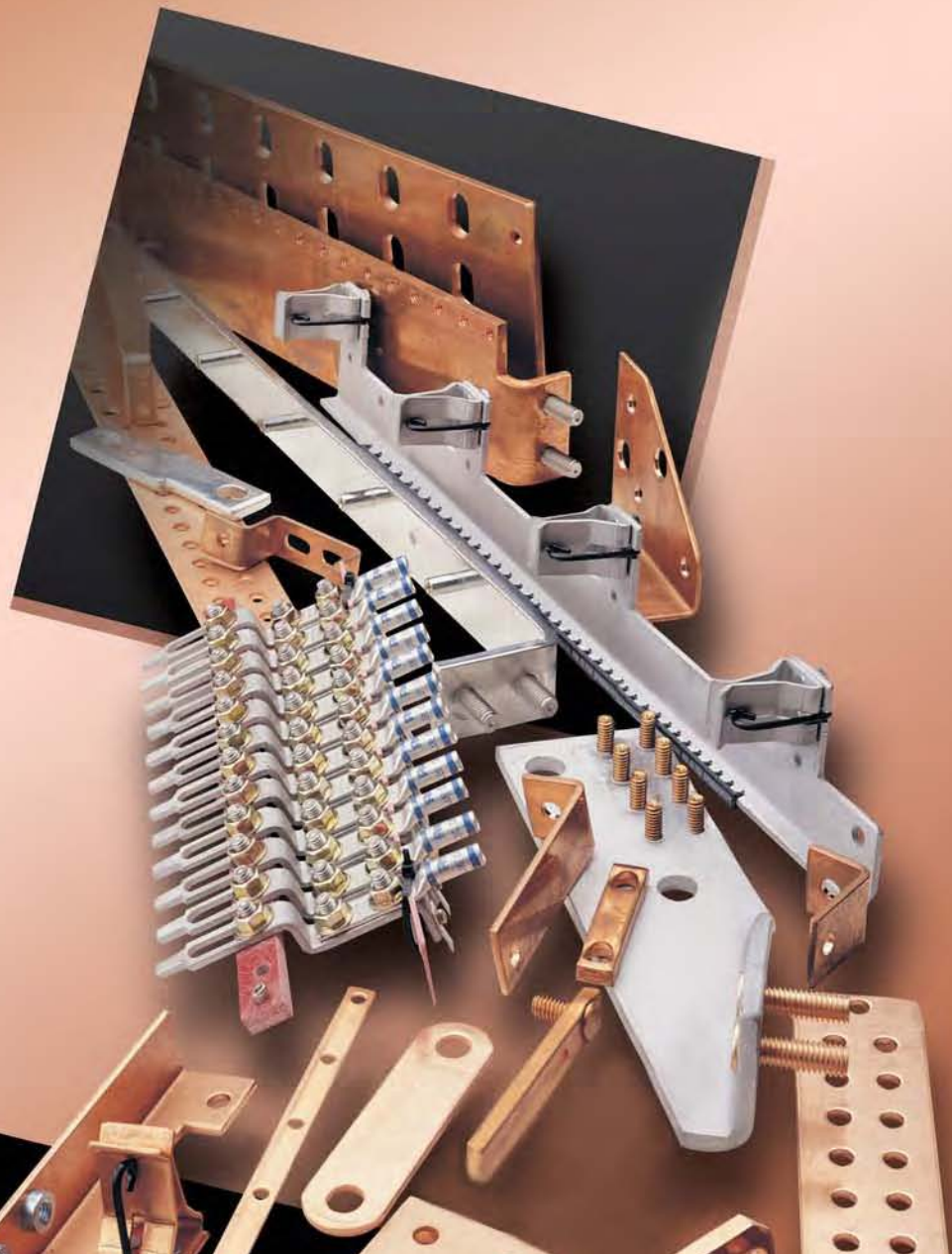

STORM COPPER COMPONENTS CO.

Copper Interconnectivity Solutions

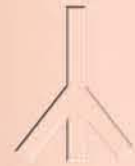



MANUFACTURING TO OEM SPECIFICATIONS AND SERVICE REQUIREMENTS

Inventory That Ensures Your Component's Availability

We maintain a standing inventory of a million pounds of copper bar and sheet in a variety of widths and thicknesses, so we can respond quickly. That gives you more production flexibility.



We maintain a million pounds of copper bar and sheet inventory at all times.

Technology That Maximizes Your Efficiency

We continually re-evaluate our production processes, and we make investments in equipment to make us faster and more cost-effective. Our strategy is to ensure your component's quality first, then look for ways we can make your parts more cost effectively.



Custom shapes and sizes are produced quickly and accurately on our Trumph Punching Machines.

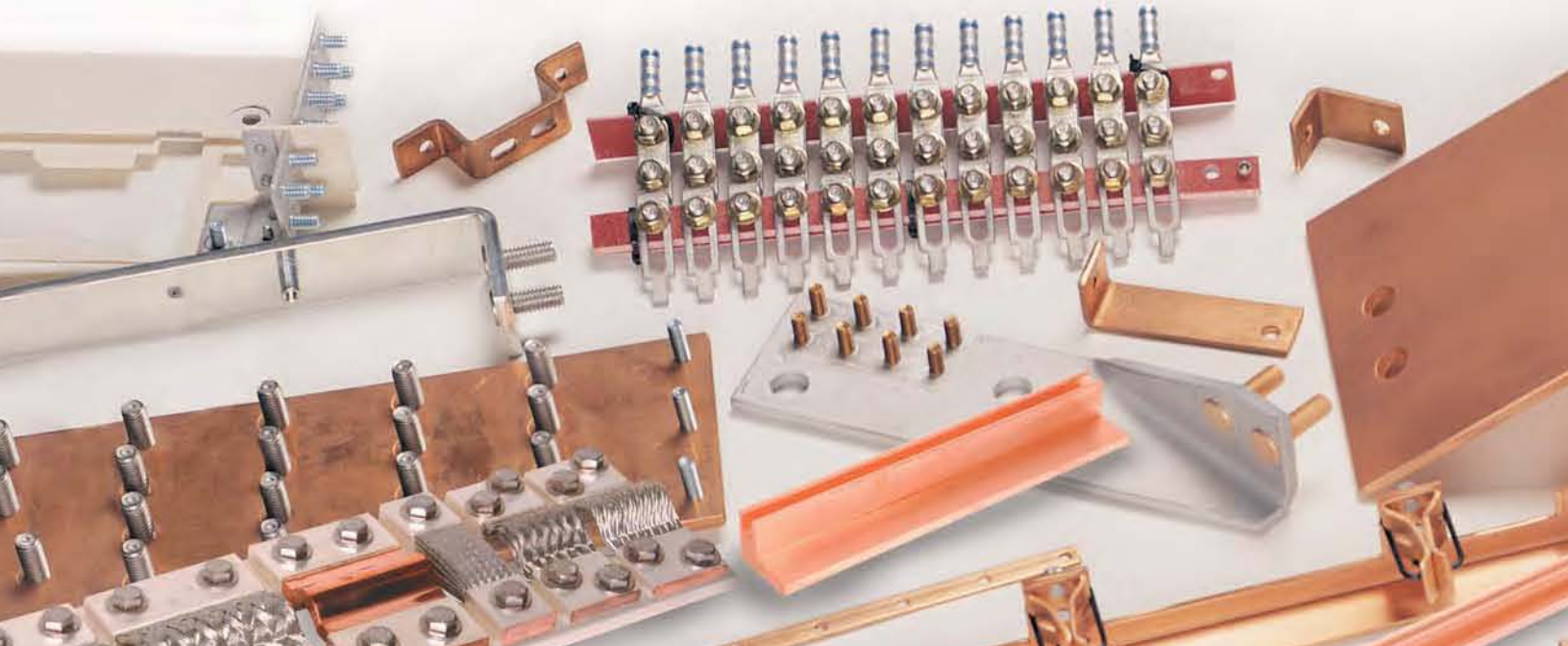



CONNECTIONS ARE OUR BUSINESS

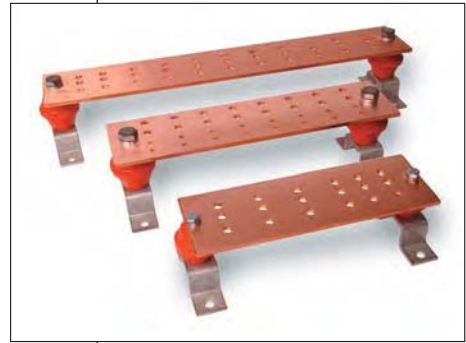
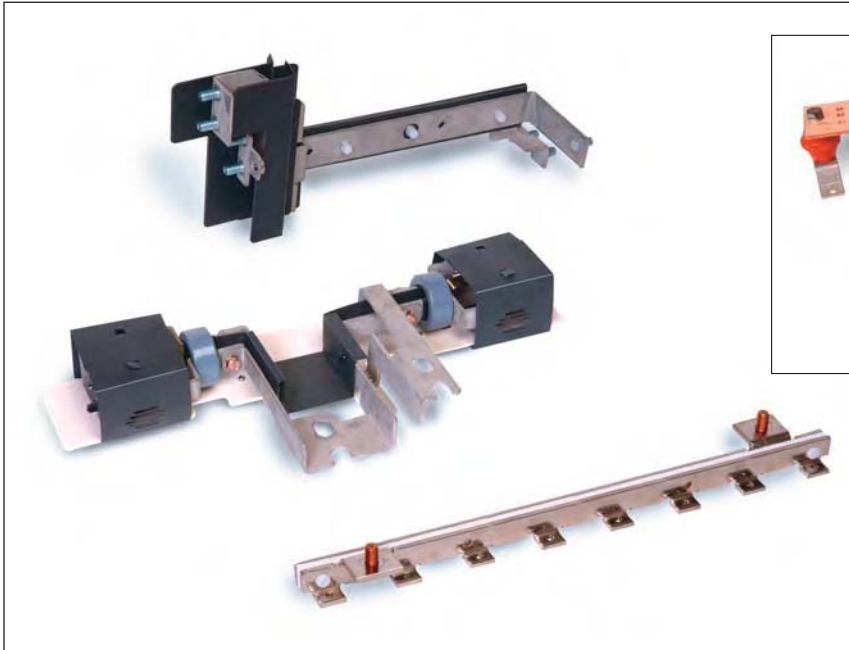

Visit www.stormcopper.com for a complete description of our standard ground bar assemblies.

Layered conductors and insulators create custom Busbar laminations.





Our materials, processes, and finished components are engineered to meet, as needed, standards required by ASME, UL, CSA, Bellcore, and other testing/standards bodies.

Since virtually every component we make is custom to a particular manufacturer or application, we have created a number of new cost effective techniques of producing connectors in both low and high volume production runs.



Our 400 ton CNC busbar press is capable of making up to ten components at once. Modular tooling allows us to set up even complicated designs in a matter of a few minutes, with minimal tool cost.

PRODUCTS



Our employees understand how to work a soft metal like copper and keep tolerances tight.

Copper Fabrication

Storm Copper Components is one of the largest copper fabricators in the United States. Virtually all of our business is copper, and we offer a variety of metalworking capabilities, all based on CNC technology. Our equipment includes shears, presses, breaks, and punching machines.





Our employees understand the technicalities of working with copper, a softer metal than steel, and one that requires some extra care in fabrication. And our proto-typing capability can usually provide sample components for testing in a matter of days.



Cable Assembly

Storm produces a full line of cable assemblies for high current applications, with a variety of lug and connector options. This was our original business, and it's one that continues to grow today.

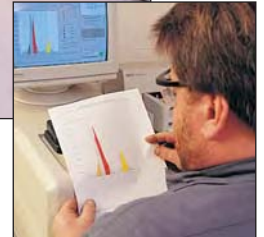

X-rays help us monitor plating thickness consistency.

Plating

Storm Copper Components developed in-house plating capabilities so we could meet the delivery requirements of our key customers. Our original bright tin plating finish has been expanded to include tin/lead, lead and silver plating.

- Tin
- Lead
- Silver
- Tin/Lead





ONLINE SUPPORT GIVES YOU AN INSTANT CONNECTION WITH US

www.stormcopper.com

Storm Copper Components works closely with its customers, and our connection on the World Wide Web gives you easy access to critical information on electrical design, plus immediate access to our company.

Our website includes conductivity tables, descriptions of our products, an inventory list of materials we have in stock, and other information that can help your procurement and scheduling.

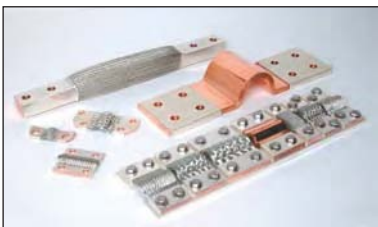

Flexible Busbars allow for vibration and movement in high current applications.

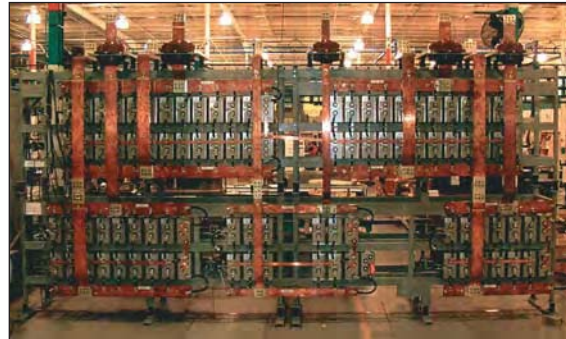

Large capacitor bank assembly used in power generation.

STORM COPPER COMPONENTS Co.

Storm Copper Components Co.
240 Industrial Drive, P.O. Box 99
Decatur, TN 37322
1-800-394-4804
Fax: 423-334-3389
www.stormcopper.com

